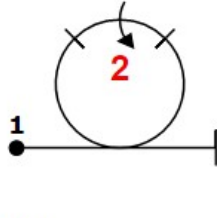
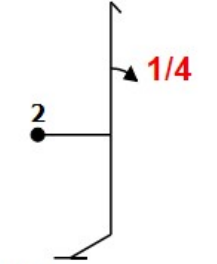
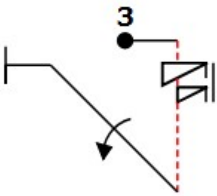
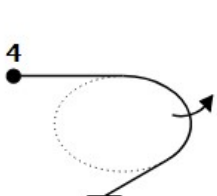
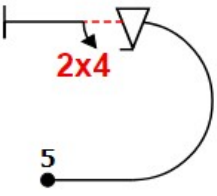

The “Known” figures specified by CIVA for powered aircraft in 2019 are:

Intermediate power / Yak-52 category

Max total K allowed = 200

 <p>Fig A 7.4.1.1(10) 9.2.3.4(9) K: 19</p>	 <p>Fig B 5.2.1.1(17) 9.1.1.1(6) K: 23</p>	 <p>Fig C 1.2.6.3(15) 9.11.1.6(3) 9.1.2.4(10) K: 28</p>	 <p>Fig D 2.1.3.3(15) K: 15</p>	 <p>Fig E 7.2.2.1(6) 9.9.3.4(11) 9.4.3.2(5) K: 22</p>
--	--	---	--	---

Advanced power category

Max total K allowed = 320

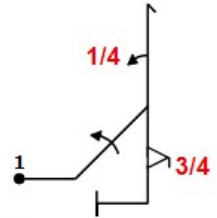
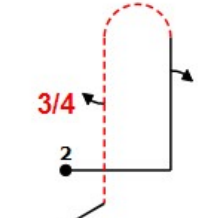
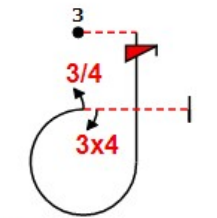
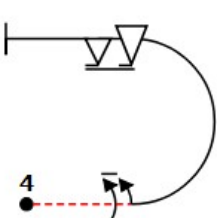
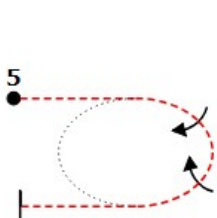
 <p>Fig A 5.3.1.1(18) 9.1.2.4(10) 9.1.1.1(6) 9.9.5.3(11) K: 45</p>	 <p>Fig B 8.4.3.1(15) 9.1.1.2(8) 9.1.5.3(6) K: 29</p>	 <p>Fig C 8.6.1.4(12) 9.12.1.4(7) 9.1.3.3(6) 9.4.3.3(8) K: 33</p>	 <p>Fig D 7.2.4.2(6) 9.1.3.6(10) 9.9.3.6(14) K: 30</p>	 <p>Fig E 2.2.5.2(23) K: 23</p>
---	--	--	--	--

Unlimited power category

Max total K allowed = 450

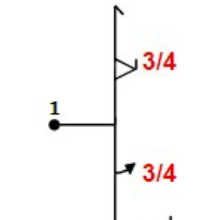
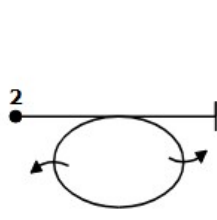
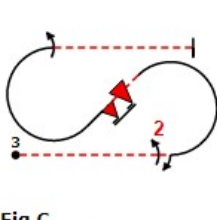
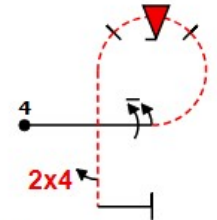
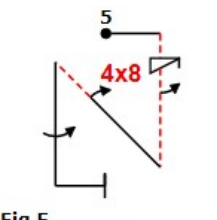
 <p>Fig A 5.2.1.3(18) 9.9.1.3(15) 9.1.5.3(6) K: 39</p>	 <p>Fig B 2.4.3.3(46) K: 46</p>	 <p>Fig C 7.5.5.2(15) 9.2.3.4(9) 9.1.3.2(4) 9.10.4.6(16) 9.1.3.4(8) K: 52</p>	 <p>Fig D 8.6.8.1(15) 9.1.3.6(10) 9.10.3.4(13) 9.4.5.2(5) K: 43</p>	 <p>Fig E 1.3.16.3(21) 9.11.1.4(5) 9.1.5.2(4) 9.8.2.2(9) 9.1.5.4(8) K: 47</p>
--	---	---	--	---

Valid from January 1st 2019