

wind/vent ← **R**

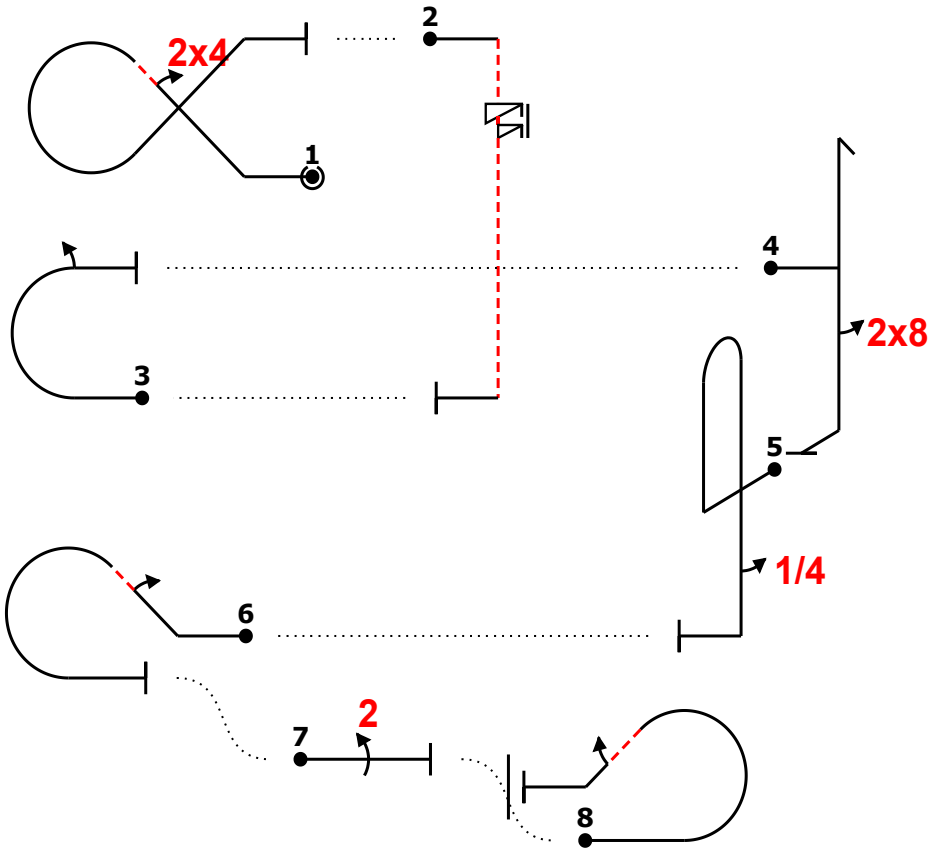

Fig	Grade	Pos	Remarks
1	.		
2	.		
3	.		
4	.		
5	.		
6	.		
7	.		
8	.		

Positioning  
15 .

Too Low		Trg Violation	
Too High		Wing Rocks	
Interruptions		Disqual Fig	
Insertions		Other(note...)	

ed ,24g (4,0) iv6s.... (-15,0) m2 (37,0) h8.' ~b..'4+' (-24,0) .....2''rc+..... (6,5) 22 (6,5) .....  
c,2.....

Fig 1	K	Fig 2	K	Fig 3	K	Fig 4	K	Fig 5	K	Fig 6	K	Fig 7	K	Fig 8	K
7.3.2.1	14	1.1.6.3	10	7.2.2.1	6	5.2.1.1	17	8.4.1.1	13	8.5.2.1	10	1.1.1.1	2	8.5.6.1	10
9.4.2.2	7	9.11.1.6	3	9.1.3.2	4	9.8.5.1	3	9.1.5.1	2	9.1.2.2	6	9.2.3.4	9	9.1.4.2	4
	<b>21</b>		<b>13</b>		<b>10</b>		<b>20</b>		<b>15</b>		<b>16</b>		<b>11</b>		<b>14</b>

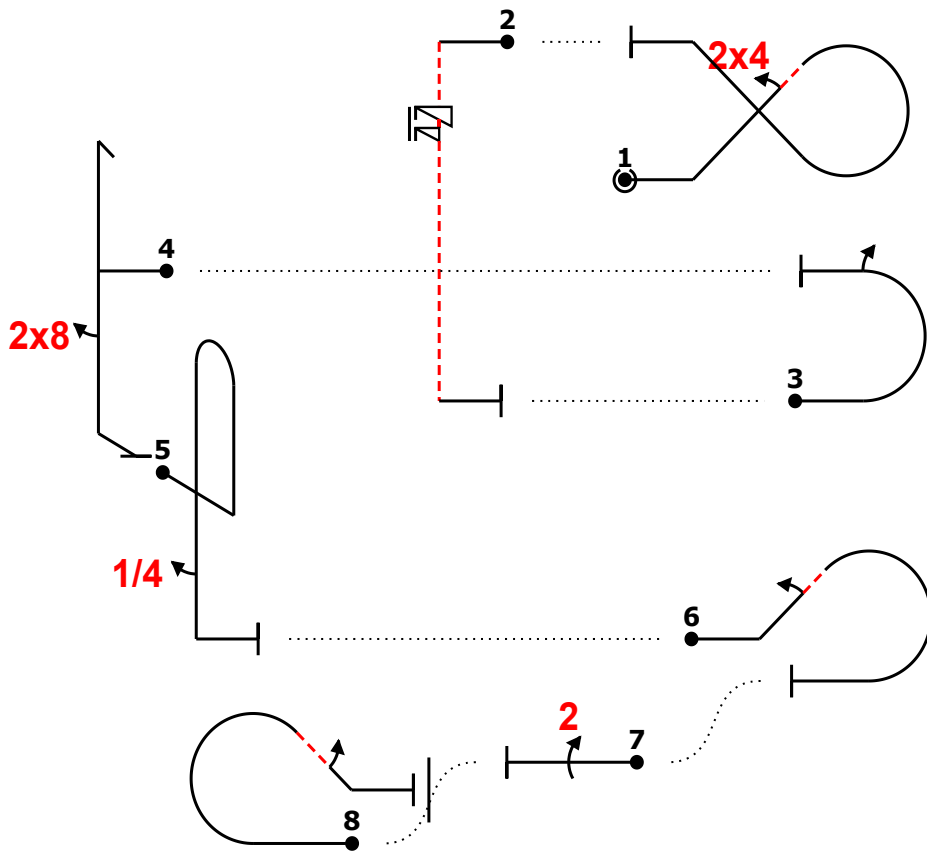
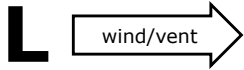

Fig	Grade	Pos	Remarks
1	.		
2	.		
3	.		
4	.		
5	.		
6	.		
7	.		
8	.		

Positioning	
<b>15</b>	.

Too Low		Trg Violation	
Too High		Wing Rocks	
Interruptions		Disqual Fig	
Insertions		Other(note...)	

ed ,24g (4,0) iv6s.... (-15,0) m2 (37,0) h8.' ~b..'4+' (-24,0) ..... ,2''rc+..... (6,5) 22 (6,5) ..... c,2.....

<b>Fig 1</b>	<b>K</b>	<b>Fig 2</b>	<b>K</b>	<b>Fig 3</b>	<b>K</b>	<b>Fig 4</b>	<b>K</b>	<b>Fig 5</b>	<b>K</b>	<b>Fig 6</b>	<b>K</b>	<b>Fig 7</b>	<b>K</b>	<b>Fig 8</b>	<b>K</b>
7.3.2.1	14	1.1.6.3	10	7.2.2.1	6	5.2.1.1	17	8.4.1.1	13	8.5.2.1	10	1.1.1.1	2	8.5.6.1	10
9.4.2.2	7	9.11.1.6	3	9.1.3.2	4	9.8.5.1	3	9.1.5.1	2	9.1.2.2	6	9.2.3.4	9	9.1.4.2	4
	<b>21</b>		<b>13</b>		<b>10</b>		<b>20</b>		<b>15</b>		<b>16</b>		<b>11</b>		<b>14</b>

Pilot:

A/C:

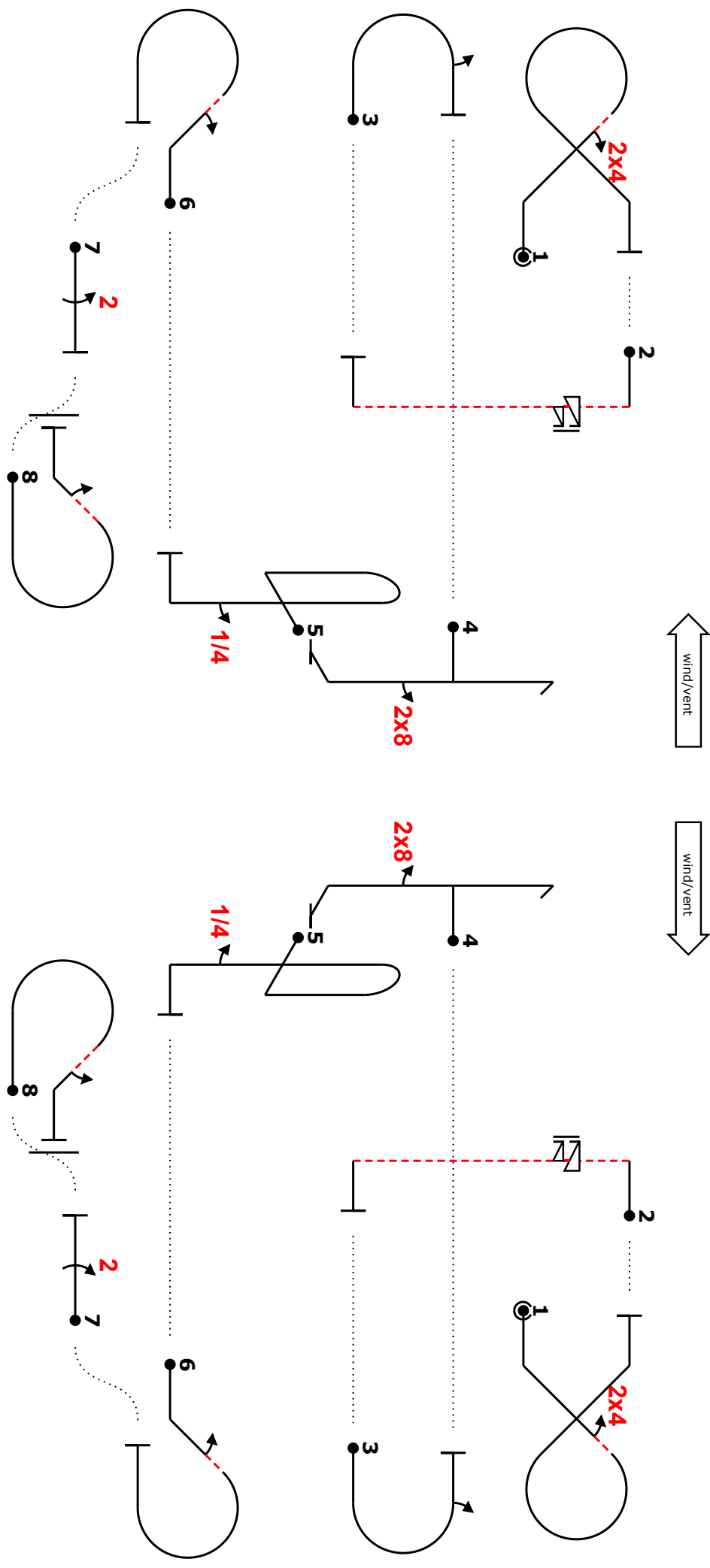

wind/vent

wind/vent

